

DV-6

6 000 lb Self-Recovery Winch



PN 854750 STD DRUM 12 V

Features Include

- Heavy duty series wound motor delivers superior torque output and faster line speed.
- Lightweight and compact design suitable for a variety of uses.
- Submersible sealed contactor handles high amps and allows higher duty cycle.
- A Stainless steel T-handle positively engages the free spool clutch through multiple evenly spaced locking holes for rapid rope payout.
- Automatic cone brake, positioned outside the drum holds the full load
- Meets international standards of CE Machinery Directive 2006/42/CE and CE Electromagnetic Compatibility Directive 2004/108/EC.
- 2" rear receiver and quick connector wiring kits for rear of vehicle as option.

Specifications

- Rated line pull: 2 722 kg (6 000 lb) single line
- Line speed (1st layer): 8.0 mpm 60 A @ no load
2.0 mpm 300 A @ full load
- Motor: 2,390 w / 3.2 hp 12V, series wound
- Gear ratio: 3-stage planetary 216:1
- Clutch (free-spooling): Rotating ring gear.
- Brake (outside the drum): Automatic, full load cone brake.
- Winch construction: Aluminum die-cast housings with steel drum.
- Drum size: Std. drum 63.5 x 151 x 125.5'
- Control: Waterproof remote w/ 5 m cord
- Wire Rope: Galvanized aircraft A7 x 19
- Size: Std drum 7.1 mm x 24.4 m
- Mounting bolts pattern: Std. drum 152.4 x 114mm
- Standard Compliance: CE Machinery Directive 2006/42/EC
CE EMC Directive 2004/108/EC

Line Pull and Rope Capacity

ROPE LAYER	PULL BY LAYER (KG / LB)	TOTAL ROPE ON DRUM (M)	
		STD DRUM	LONG DRUM
1	2 722 / 6 000	3.8	7.0
2	2 266 / 4 995	8.4	15.4
3	1 941 / 4 279	13.7	25.2
4	1 697 / 3 742	19.8	30.5
5	1 508 / 3 325	24.4	X

LINE SPEED & AMP DRAW (1st Layer of Wire Rope on the Drum)

LINE PULL (KG / LB)	LINE SPEED (MPM)	AMP DRAW (12V)
No Load	8.0	60
907 / 2 000	5.2	150
1 814 / 4 000	3.1	240
2 722 / 6 000	2.0	300

Dimensions mm/inch

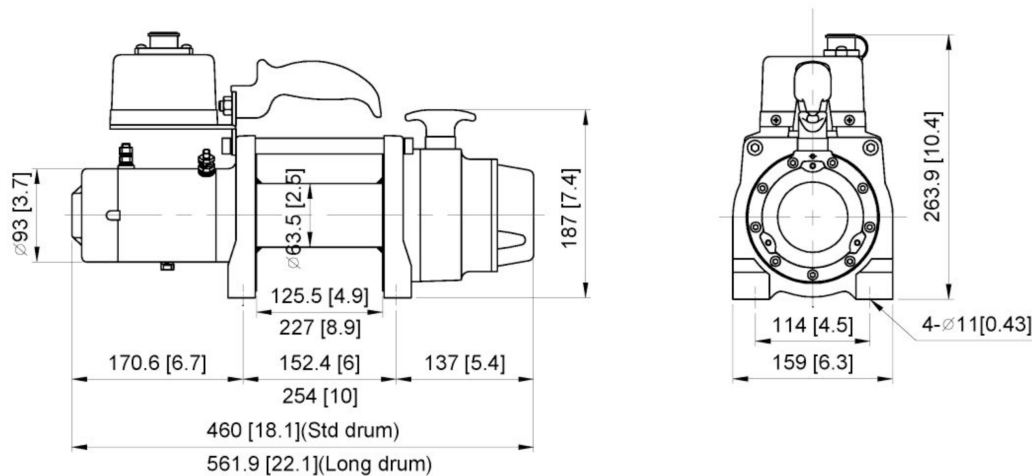

Packaging (Std Drum)

- Winch Weight (including rope): 22.8 kg
- Gross Weight: 28.4 kg
- Box Dimensions: 505 x 210 x 340 mm

Accessories

- Wire rope w/safety hook
- Remote control w/ 5 m cord
- Roller fairlead
- Mounting hardware
- Control box w/ handle for PN 854750

WARNING!

- Do not use winch to transport, lift or otherwise move personnel.
- The rated line pull shown is based on the first layer of wire rope on the drum.
- The wire rope must remain on the drum at all time with at least 5 wraps.

Warranty

Limited lifetime warranty for mechanical components and one(1) year warranty for electrical components from date of purchase. Wire/Synthetic ropes are not included under warranty.